

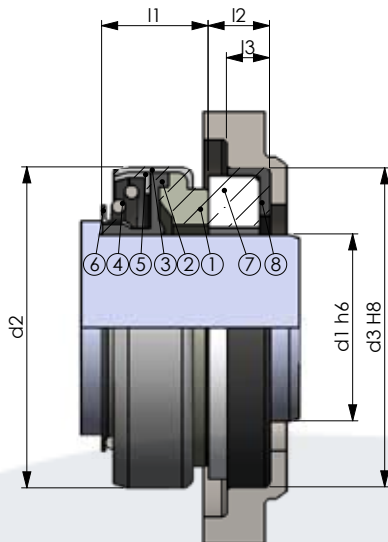

## TIPO BD

Compacto de Fole de Borracha

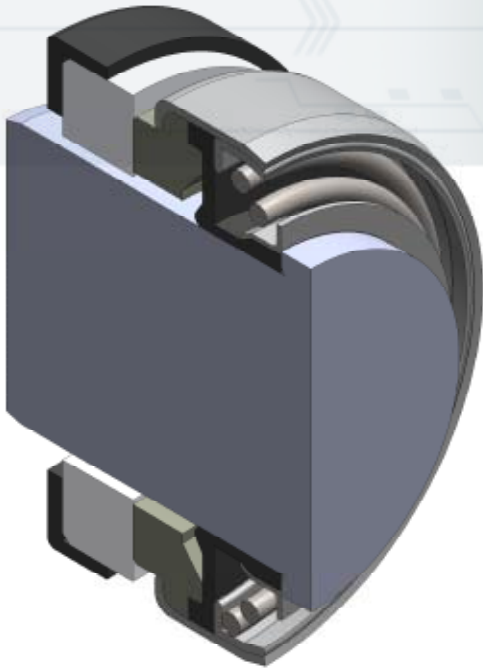

Tipo BD

Selo mecânico compacto componente simples de mola única rotativa e fole de borracha, não balanceado, independente do sentido de rotação. Ideal para equipamentos com espaço para selo mecânico reduzido devido seu comprimento de trabalho curto quando comparado a outros selos mecânicos.

Suporte para face rotativa estampada em aço inox possibilita fabricação a baixo custo e capaz de suportar grande diversidade de aplicação.



### DESCRIÇÃO ITENS

- 1 – Face Rotativa
- 2 – Fole de borracha
- 3 – Suporte para face
- 4 – Mola
- 5 – Suporte para fole de borracha
- 6 – Suporte para mola
- 7 – Sede estacionária
- 8 – Anel copo

### LIMITES DE OPERAÇÃO

Pressão: 6bar  
Temperatura: -20°C a 160°C  
Velocidade: 10m/s

Limites teóricos variam em função da aplicação e podem ser menores se combinados. Consulte sua aplicação com a Flex-A-Seal.

## OPÇÕES DE MATERIAIS

### Faces

Cerâmica

Grafite

Carbeto de Silício

Carbeto de Tungstênio

### Elastômeros

EPDM

Viton

Buna-N

### Mola

Aço Inox

Combinações possíveis de materiais			
Rotativa	Sedes		
	Cerâmica	Silício	Tungstênio
Grafite	X	X	X
Carbeto de Silício		X	
Carbeto de Tungstênio			X

d1	d2	d3	l1	l2	l3
8a	20,0	26,0	11,0	4,0	3,0
8b	20,0	22,0	11,0	4,0	3,0
8c	24,0	26,0	11,0	8,0	6,0
9	24,0	26,0	11,0	8,0	6,0
10	24,0	26,0	11,0	8,0	6,0
11	24,0	26,0	11,0	8,0	6,0
12a	24,0	26,0	11,0	8,0	6,0
12b	24,0	26,0	13,0	8,0	6,0
12c	32,0	35,0	13,0	8,0	6,0
13	24,0	26,0	13,0	8,0	6,0
14a	28,0	25,0	13,0	7,0	5,0
14b	28,0	28,5	13,0	8,0	6,0
14c	32,0	29,5	13,0	8,0	6,0
14d	32,0	35,0	13,0	8,0	6,0
15a	32,0	29,5	13,0	8,0	6,0
15b	32,0	38,0	13,0	8,0	6,0
15c	35,0	38,0	13,0	8,0	6,0
16a	32,0	29,5	13,0	8,0	6,0
16b	35,0	38,0	13,0	8,0	6,0
16c	39,0	38,0	13,0	8,0	6,0
16d	39,0	42,0	13,0	8,0	6,0
17	39,0	42,0	13,0	8,0	6,0
18	39,0	42,0	13,0	8,0	6,0
19	39,0	42,0	13,0	8,0	6,0
20a	39,0	42,0	13,0	8,0	6,0
20b	42,0	45,0	13,0	10,0	8,0
22	42,0	45,0	13,0	10,0	8,0
23	47,0	50,0	14,0	10,0	8,0
24	47,0	50,0	14,0	10,0	8,0
25a	42,0	50,0	14,0	10,0	8,0
25b	47,0	50,0	14,0	10,0	8,0
26	47,0	50,0	14,0	10,0	8,0
28	54,0	57,0	15,0	10,0	8,0
30	54,0	57,0	15,0	10,0	8,0
32	54,0	57,0	15,0	10,0	8,0
35	60,0	63,0	16,0	10,0	8,0
38	65,0	68,0	18,0	12,0	9,0
40	65,0	68,0	18,0	12,0	9,0
45	70,0	73,0	20,0	12,0	9,0
50	85,0	88,0	23,0	15,0	12,0
55	85,0	88,0	23,0	15,0	12,0
60	105,0	110,0	30,0	15,0	12,0
65	105,0	30,0	110,0	15,0	12,0
70	105,0	110,0	32,0	15,0	12,0

Dimensões em milímetros  
Tolerâncias para comprimento de trabalho  
±0,5mm

Caso sua aplicação seja diferente, consulte a Flex-A-Seal

Distribuído por:



ISO 9001  
BUREAU VERITAS  
Certification



#### BRASIL

Rua Javaés, 441/443  
Bom Retiro - SP  
CEP: 01130-010  
Fone/Fax: (11) 3736-7373  
e-mail: vendas@flexaseal.com.br  
www.flexaseal.com.br

#### USA

1 Jackson Street PO Box 184  
Essex Junction, VT 05453-0184 USA  
Phone: 1-800-426-3594 - 1-802-878-8307  
Fax: 1-802-878-2479  
e-mail: sales@flexaseal.com  
www.flexaseal.com